



早安股份有限公司
YELLOW STONE CORP.

● FEATURES

- 0.20 inch (5.08 mm) Digit Height.
- SMD type.
- Low current operation.
- Gray face, White segment.
- RoHS compliant, Pb Free.

● DESCRIPTION

The YSS-2010SY-GW & YSS-2011SY-GW are 0.20 inch (5.08 mm) height Single digit 7-segment displays.

This device utilizes Super Bright Yellow LED chip which are made from AlGaInP On a transparent GaAs, substrate.

The display has Gray face, White segment.

● DEVICE

PART NO	DESCRIPTION
YSS-2010SY-GW	Common Anode
YSS-2011SY-GW	Common Cathode

RoHS Compliance



Pb free.





早安股份有限公司
YELLOW STONE CORP.

● MECHANICAL DIMENSIONS

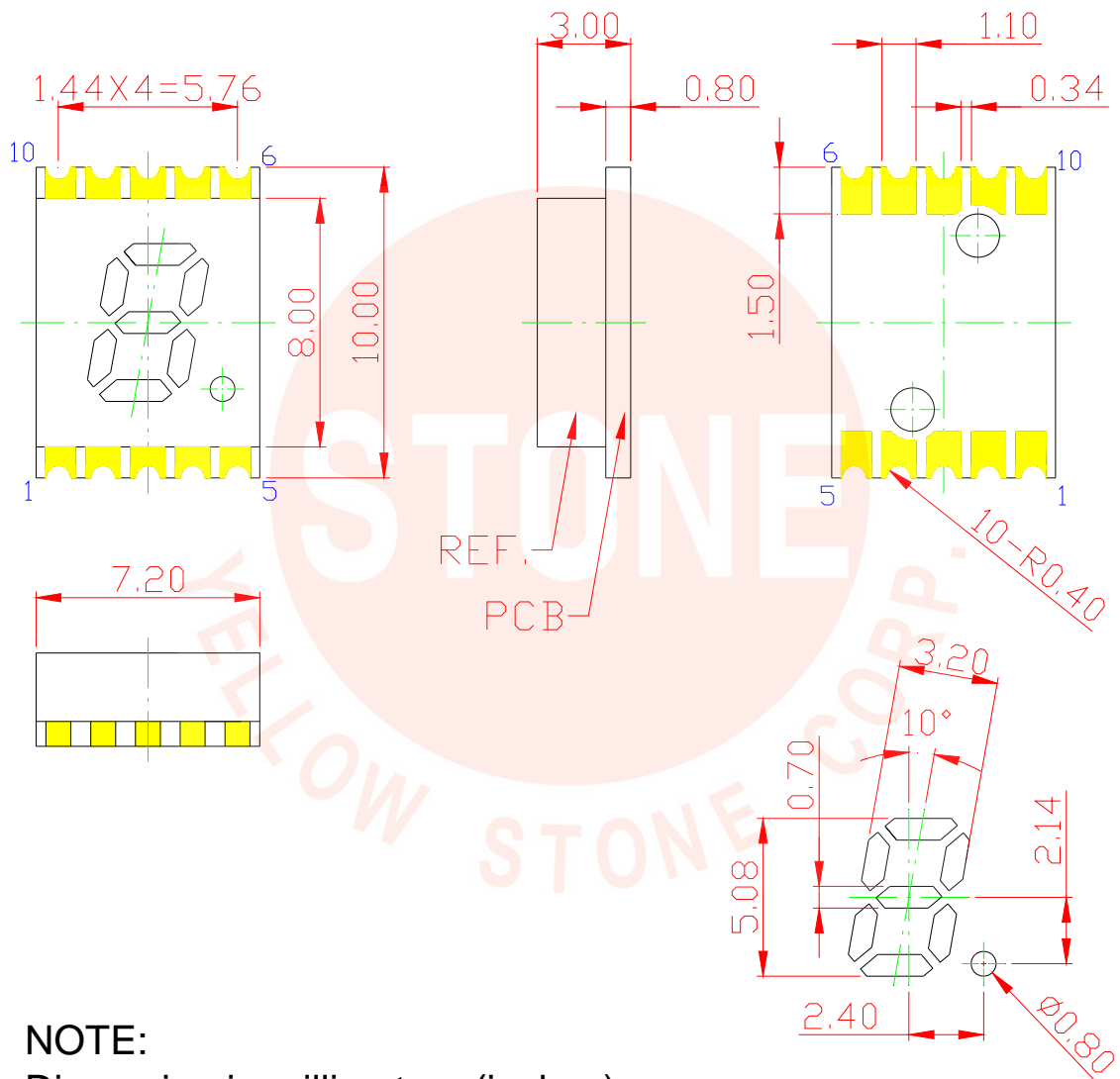

NOTE:

Dimension in millimeters (inches),
and tolerances are $\pm 0.25\text{mm}$ (.01") specified.

● **TYPICAL INTERNAL EQUIVALENT CIRCUIT**

Recommended Soldering Pattern

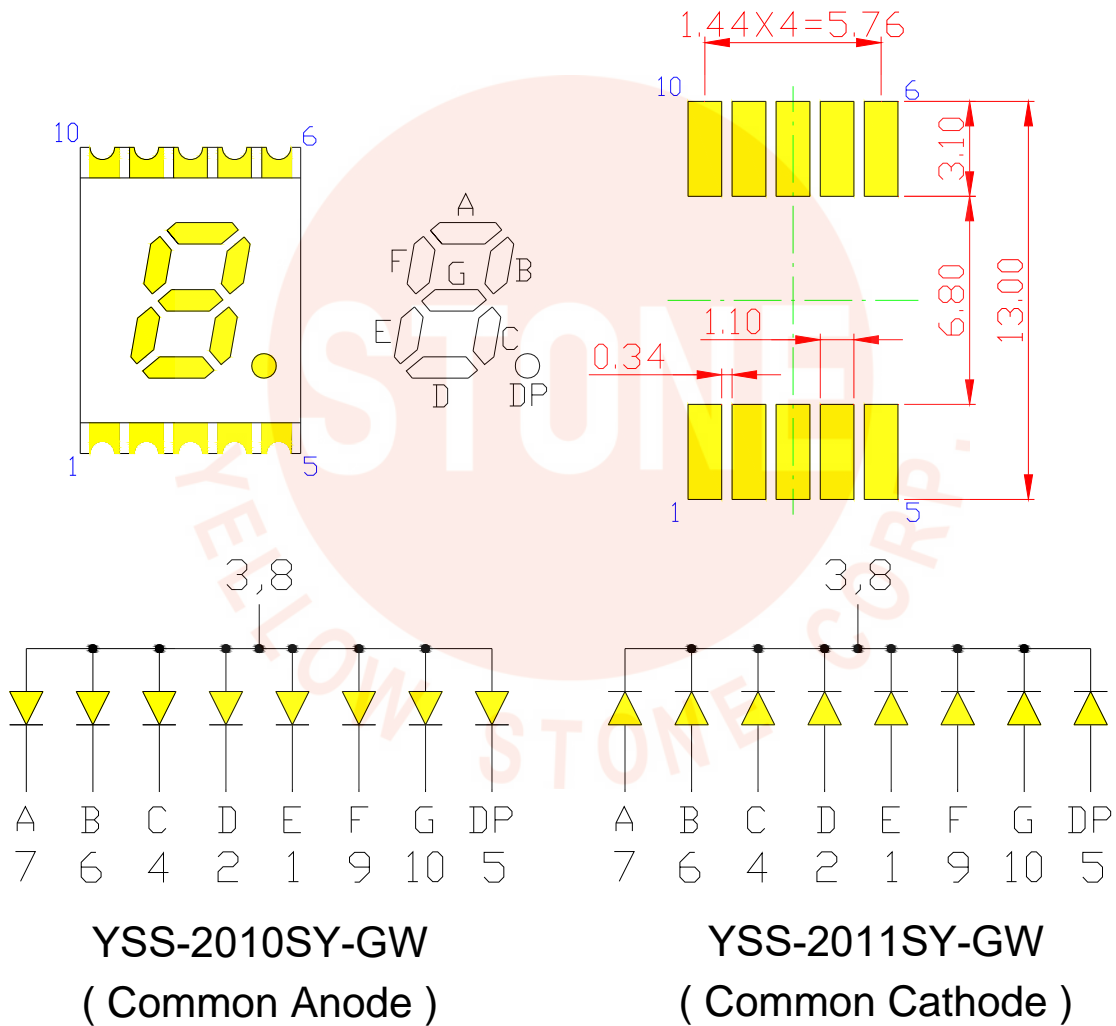

● **SY: SUPER BRIGHT YELLOW (AlGaInP/GaAs)**

ABSOLUTE MAXIMUM RATING AT Ta=25°C

Parameter	Symbol	Maximum Rating	Unit
Power dissipation	P_{AD}	70	mW
Derating liner from 25°C	-	0.28	mA / °C
Continuous forward current	I_{AF}	25	mA
Peak current (duty cycle 1/10, 1kHz)	I_{PF}	90	mA
Reverse voltage	V_R	5	V
Operating temperature	T_{OPR}	-40 to +105	°C
Storage temperature	T_{STG}	-40 to +105	°C

ELECTRICAL - OPTICAL CHARACTERISTICS AT Ta=25°C

Characteristic	Symbol	Condition	Min.	Type.	Max.	Unit
Forward Voltage, (Per Dice)	V_F	$I_F=20mA$	-	2.0	2.4	V
Reverse Current, (Per Dice)	I_R	$V_R=5V$	-	-	10	μA
Peak Wavelength	λ_P	$I_F=20mA$	-	593	-	nm
Dominant Wavelength	λ_D	$I_F=20mA$	585	-	595	nm
Luminous Intensity	I_v	$I_F=20mA$	15	-	45	mcd
Spectral radiation bandwidth	$\Delta\lambda$	$I_F=20mA$	-	20	-	nm



早安股份有限公司
YELLOW STONE CORP.

● SY: BIN GRADE (Unit : mcd) 20mA

Super Bright Yellow	H	I	J
	15.0 – 25.0	25.1 -35.0	35.1 -45.0

● SY: HUE GRADE (λ_D : nm)

1	2	3
585.0 – 588.0	588.1 – 592.0	592.1 – 595.0

● AVAILABLE BIN / HUE TABLE

H1	H2	H3
I1	I2	I3
J1	J2	J3

● **SY: SUPER BRIGHT YELLOW (AlGaInP/GaAs) CURVE**

Typical Electro-optical Characteristic Curves
(25 °C Free Air Temperature Unless Otherwise Specified)

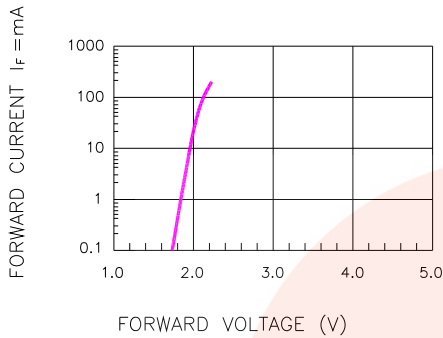

Fig.1 FORWARD CURRENT VS. FORWARD VOLTAGE

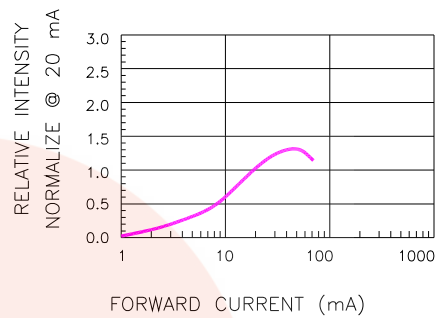

Fig.2 RELATIVE INTENSITY VS. FORWARD CURRENT

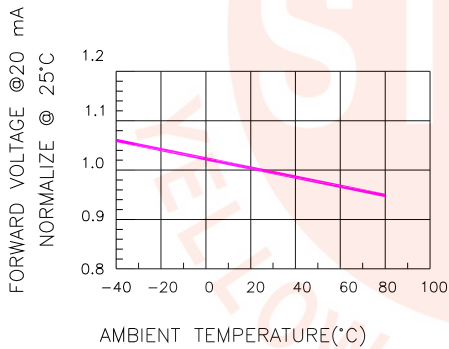

Fig.3 FORWARD VOLTAGE VS. TEMPERATURE

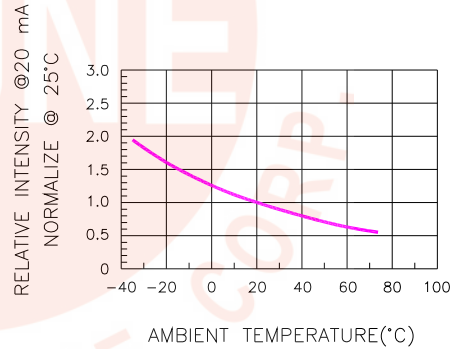

Fig.4 RELATIVE INTENSITY VS. TEMPERATURE

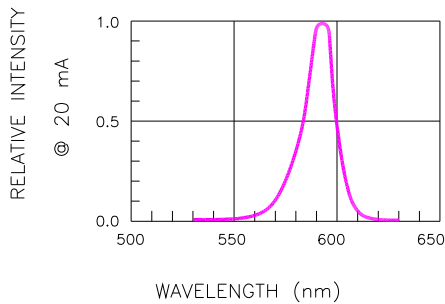

Fig.5 RELATIVE INTENSITY VS. WAVELENGTH

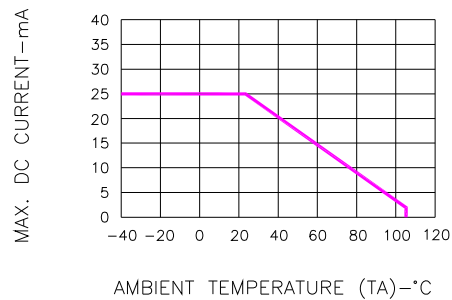
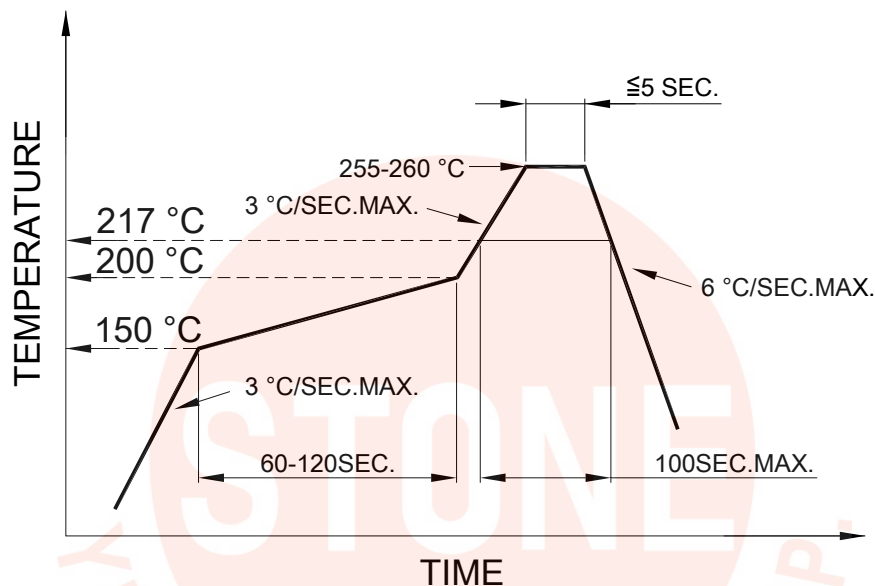

Fig.6 MAX. ALLOWABLE DC CURRENT VS. AMBIENT TEMPERATURE

● SMT REFLOW SOLDERING INSTRUCTIONS

SMT Soldering Profile

Pb free reflow soldering Profile



- We recommend the reflow temperature 245°C (+/- 5°C).
The maximum soldering temperature should be limited to 260°C.
- Number of reflow process shall be 2 times or less.

● SOLDERING IRON

Basic spec is ≤ 4 sec when 260°C. If temperature is higher, time should be shorter (+10°C → 1 sec). Power dissipation of Iron should be smaller than 15W, and temperature should be controllable. Surface temperature of the device should be under 230°C.

● REWORK

- Customer must finish rework within 3 sec. under 350°C.
- The head of soldering iron cannot touch copper foil.

● REEL DIMENSIONS

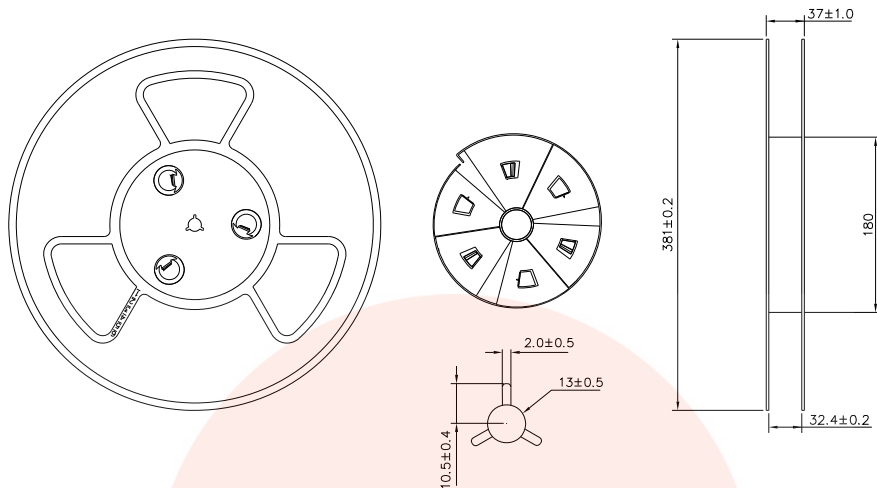

● PACKING & LABEL SPECIFICATIONS

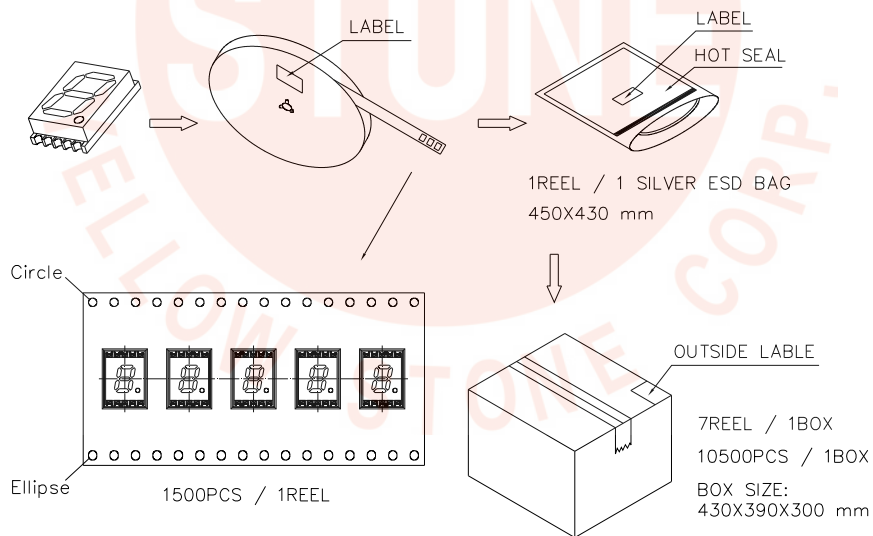

● STORAGE CONDITION

In factory original sealed bag package

TEMPERATURE CONDITION	HUMIDITY CONDITION
5°C ~ 30°C	Below 60%RH

After opened and not in factory original sealed bag package

TEMPERATURE CONDITION	HUMIDITY CONDITION	STORAGE TIME
5°C ~ 30°C	Below 60%RH	Within 4 weeks (MSL as level 2a)